



14+



2



2,4m



1 = 2,4m
2 = 0,65m
3 = 2,51m

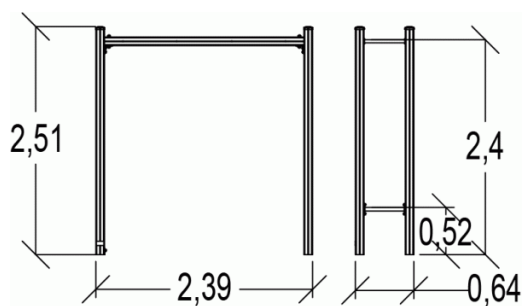
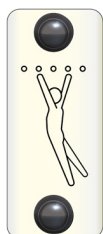

Fonctions ludiques : 3

Traverser



x1

Se suspendre



x1

Tractions



x1



Installation de l'équipement

IMPORTANT : Se référer impérativement à la notice de montage pour le dimensionnement des zones de sécurité

— Zone d'impact (surface normative minimale)

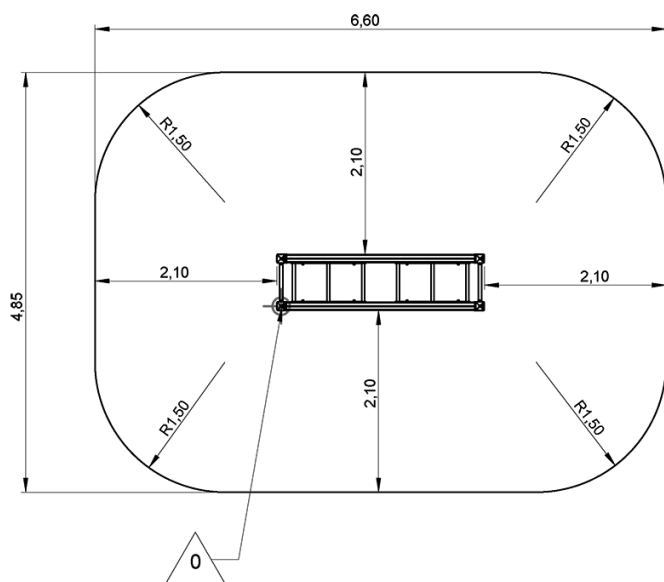
- - - Espace libre



		
1	2,4m	30m ²



2



01h45



0.1m³



18m²



133kg



20kg





Équation sportive

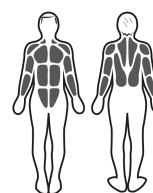

Stimulation musculaire

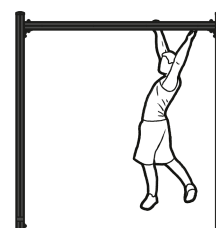

Mouvements

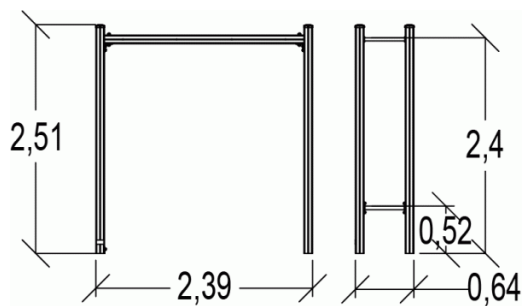

► **Activités Sportives :** 3

Traverser



Se suspendre



Tractions



renforcement musculaire cardio

équilibre

coordination

► Installation de l'équipement

IMPORTANT : Se référer impérativement à la notice de montage pour le dimensionnement des zones de sécurité

———— Zone d'impact (surface normative minimale)

- - - - Espace libre

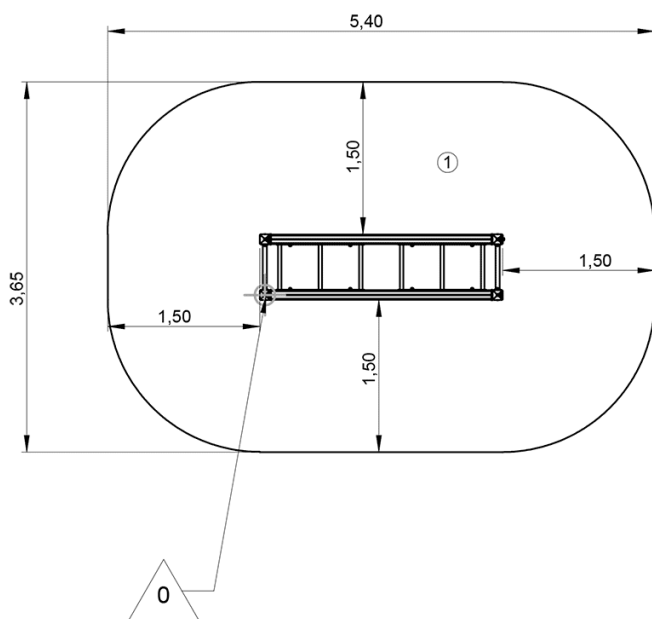

1	1,4m	18m ²



2



01h45



0.1m³



18m²



133kg



20kg

