



14+



2



1,8m



1 = 2,3m
2 = 0,1m
3 = 2,02m

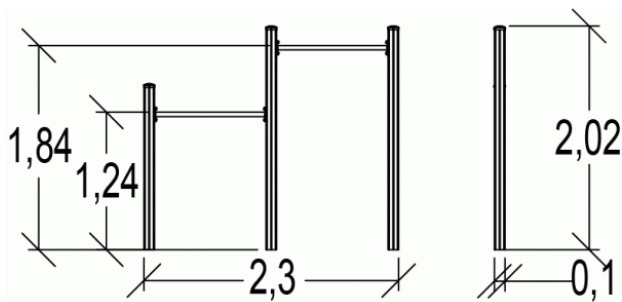

Fonctions ludiques : 4

Se suspendre



x2

Tractions



x2

Installation de l'équipement

IMPORTANT : Se référer impérativement à la notice de montage pour le dimensionnement des zones de sécurité

— Zone d'impact (surface normative minimale)

- - - Espace libre

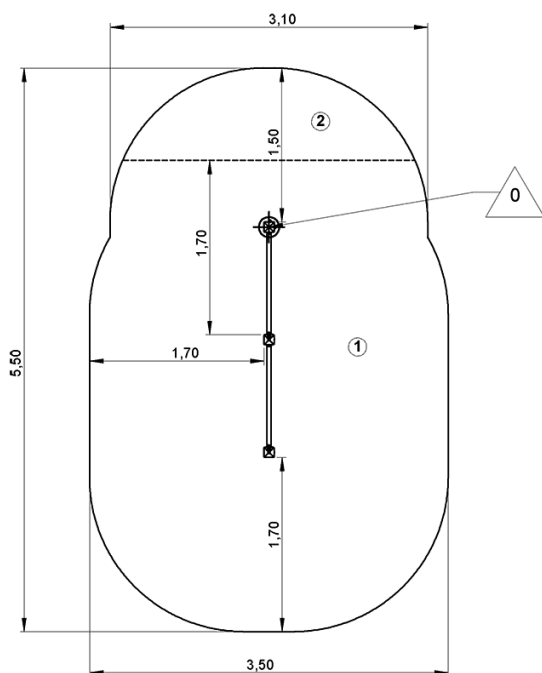

1	1,2m	2m ²
2	1,8m	15m ²



1

01h00

0.1m³

14.5m²

54kg

17kg

EN

1176

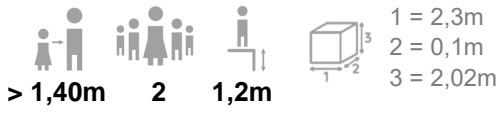

Équation sportive

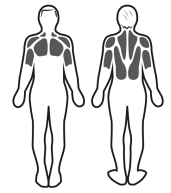

Stimulation musculaire

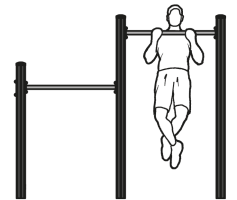

Mouvements

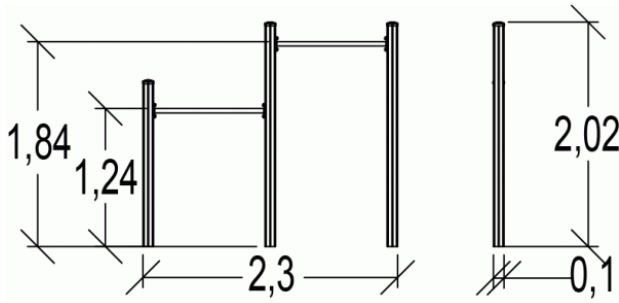

► **Activités Sportives :** 4

Se suspendre



Tractions



renforcement musculaire cardio

équilibre

coordination



► Installation de l'équipement

IMPORTANT : Se référer impérativement à la notice de montage pour le dimensionnement des zones de sécurité

— Zone d'impact (surface normative minimale)

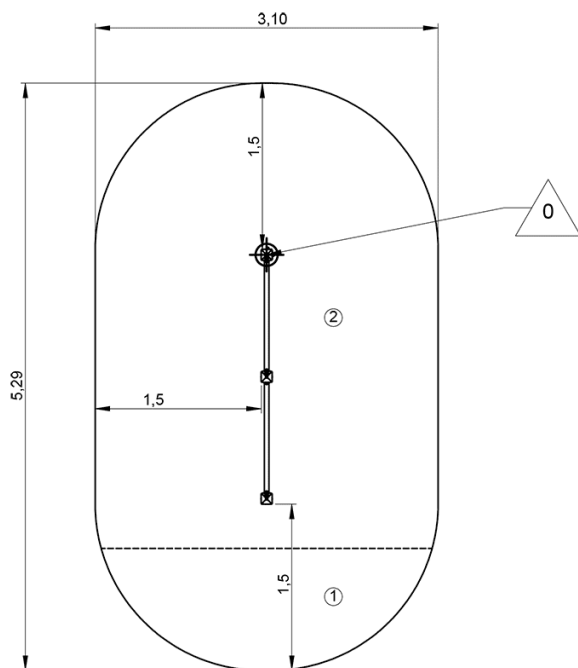
- - - Espace libre



		
1	0,84m	3m ²
2	1,24m	12m ²



1



01h00



0.1m³



14.5m²



54kg



17kg

