



6+



36



2,32m



1 = 5,63m
2 = 2,53m
3 = 3,01m



Inclusion motrice
Inclusion sensorielle
Inclusion mentale

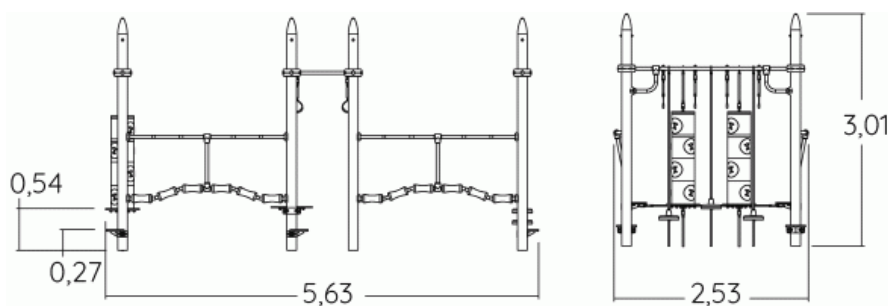

Fonctions ludiques : 19

S'équilibrer



Traverser



Se suspendre



Éléments constitutants

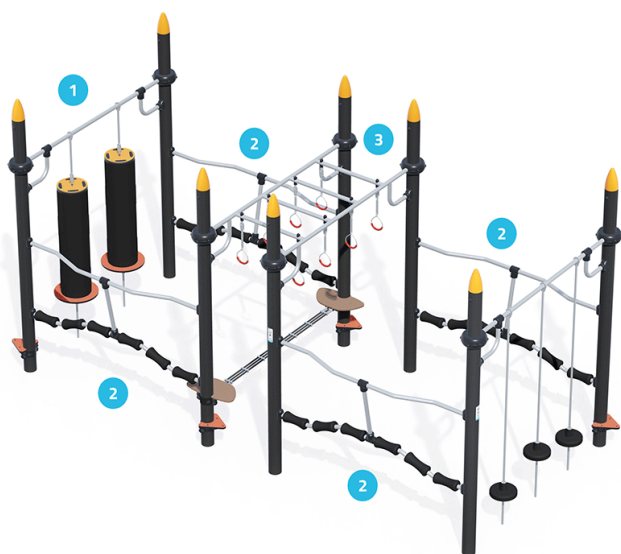

- ① Rouleaux suspendus
- ② Passerelle "Crabe"
- ③ Passerelle anneaux
- ④ Pôles suspendus

Installation de l'équipement

IMPORTANT : Se référer impérativement à la notice de montage pour le dimensionnement des zones de sécurité

- Zone d'impact (surface normative minimale)
- Espace libre

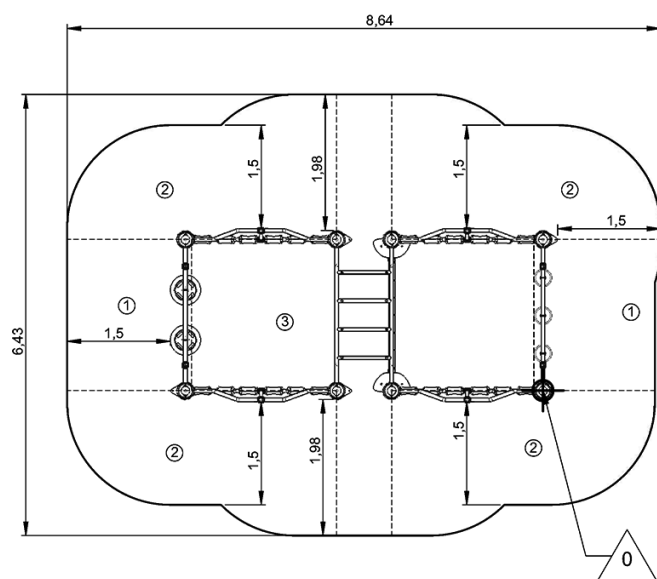

1	0,6m	8m ²
2	0,86m	27,5m ²
3	2,32m	14,5m ²



2

09h00

0.65m³

50m²

625kg

107kg

EN

1176

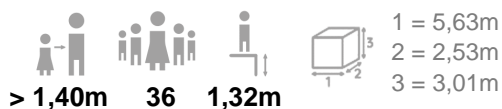

Équation sportive

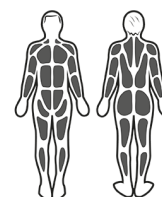

Stimulation musculaire

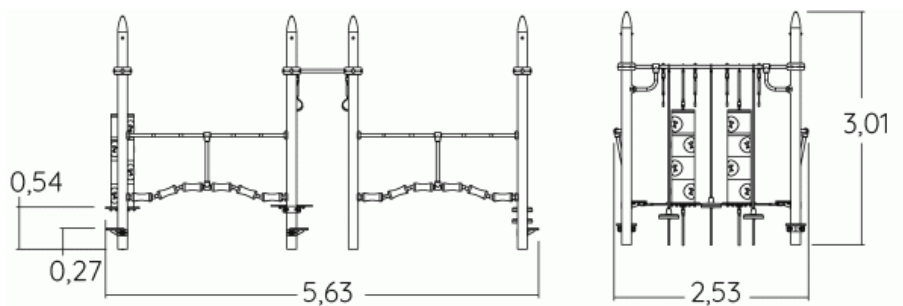

► **Activités Sportives :** 19

S'équilibrer

Traverser

Se suspendre



renforcement musculaire

cardio

équilibre

coordination

Eléments constituant

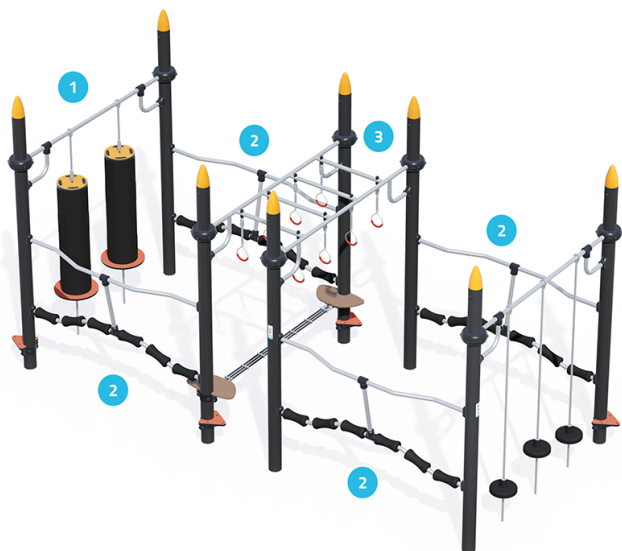

- ① Rouleaux suspendus
- ② Passerelle "Crabe"
- ③ Passerelle anneaux
- ④ Piliers suspendus

Installation de l'équipement

IMPORTANT : Se référer impérativement à la notice de montage pour le dimensionnement des zones de sécurité

- Zone d'impact (surface normative minimale)
- Espace libre

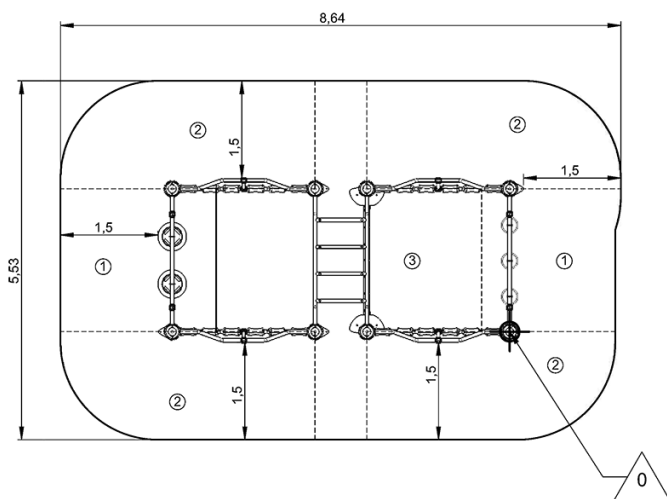

1	0,6m	10,5m ²
2	0,86m	25,5m ²
3	1,32m	12m ²



2



09h00



0.65m³



50m²



625kg



107kg

