



6+



4



2,32m



1 = 2,46m  
2 = 1,04m  
3 = 3,01m

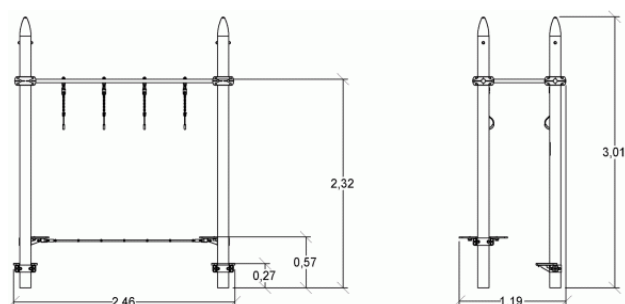

## Fonctions ludiques : 6

S'équilibrer



x1

Traverser



x3

Se suspendre



x2

## Installation de l'équipement

**IMPORTANT : Se référer impérativement à la notice de montage pour le dimensionnement des zones de sécurité**

— Zone d'impact (surface normative minimale)

- - - Espace libre

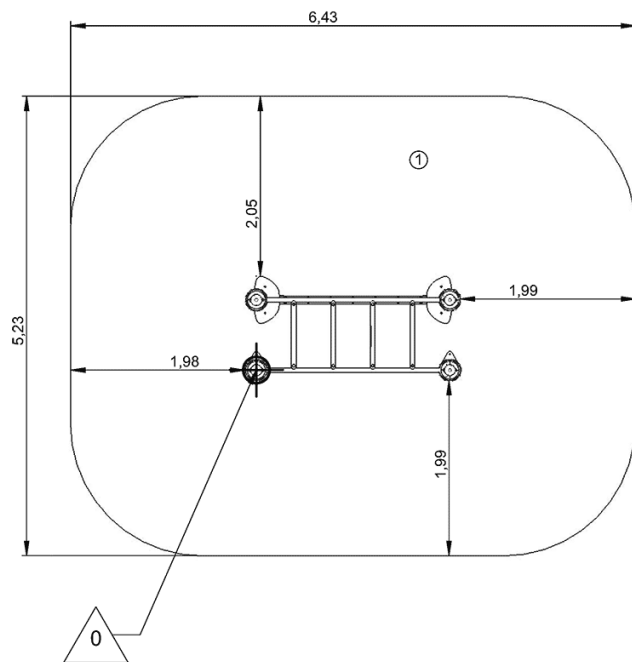

1	2,32m	32m <sup>2</sup>



2



02h00



0.26m<sup>3</sup>



32m<sup>2</sup>



157kg



25kg



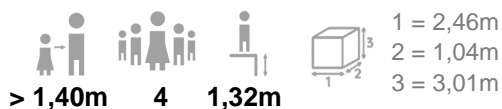

Équation sportive

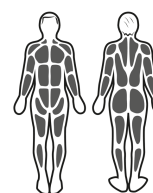

Stimulation musculaire

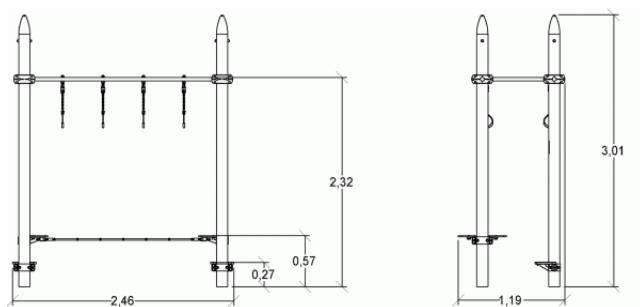

► Activités Sportives : 6

S'équilibrer



Traverser



Se suspendre



renforcement musculaire cardio

équilibre

coordination



## ► Installation de l'équipement

**IMPORTANT : Se référer impérativement à la notice de montage pour le dimensionnement des zones de sécurité**

— Zone d'impact (surface normative minimale)

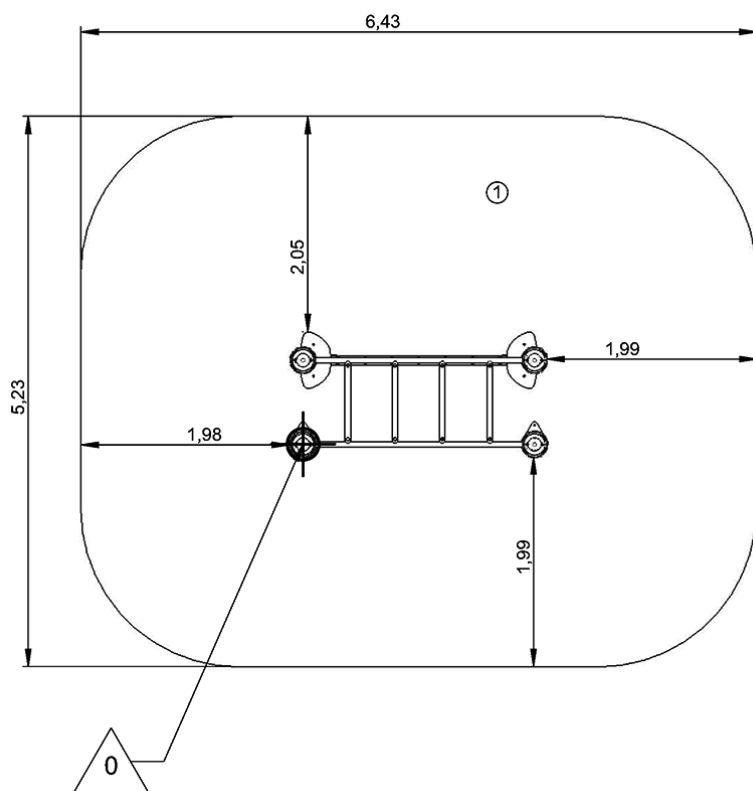
- - - Espace libre



		
1	1,32m	21m²



2



02h00



0.26m³



32m²



157kg



25kg

